

直流风机的型号说明

www.cnvcb.com

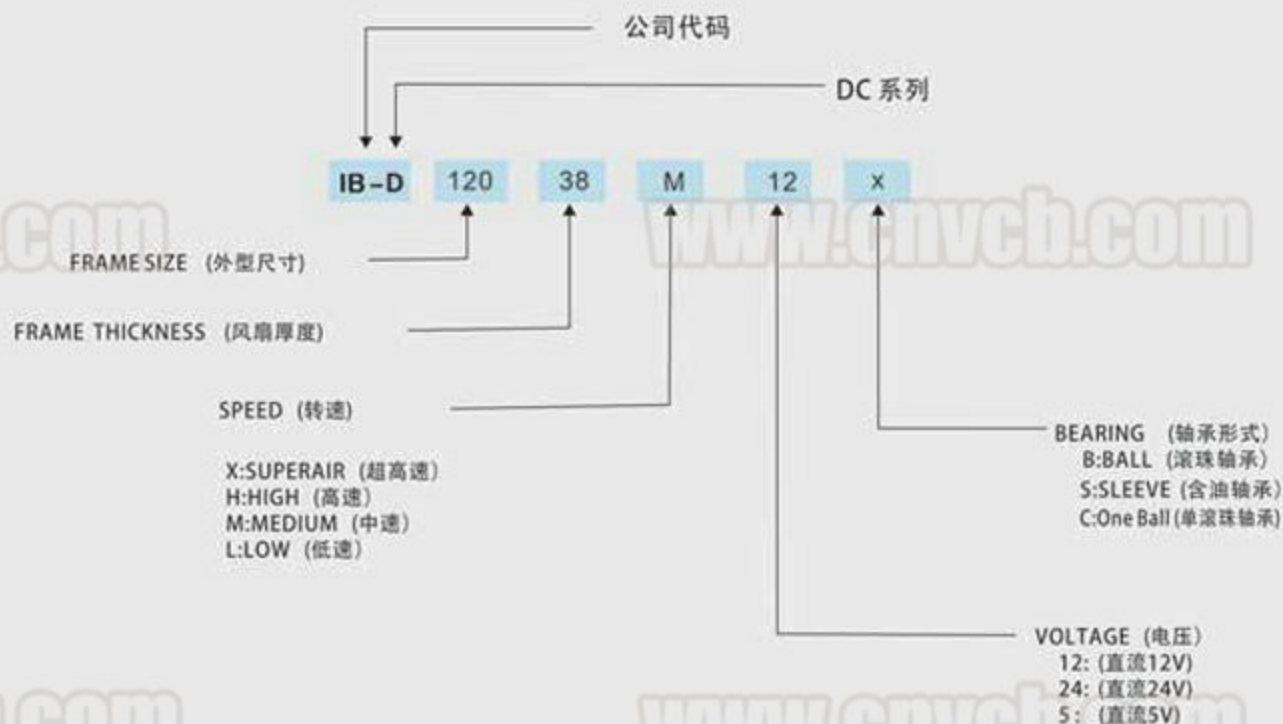

直流风机的内部结构

马达：无刷电机
风扇框架：注塑一次成型,PBT+30%玻纤+VO级阻燃剂
风叶：注塑一次成型,PBT+30%玻纤+VO级阻燃剂
风向旋转：从扇叶方向看为逆时针
绝缘电阻：大于500兆欧以上
轴承：高精度进口滚珠轴承;低噪声进口含油轴承

运行温度：-10摄氏度到+70摄氏度
储存温度：-40摄氏度到+70摄氏度
工作寿命：滚珠轴承 含油轴承 环境温度
50000小时 30000小时 25℃
电压范围：额定电压±15%

www.cnvcb.com

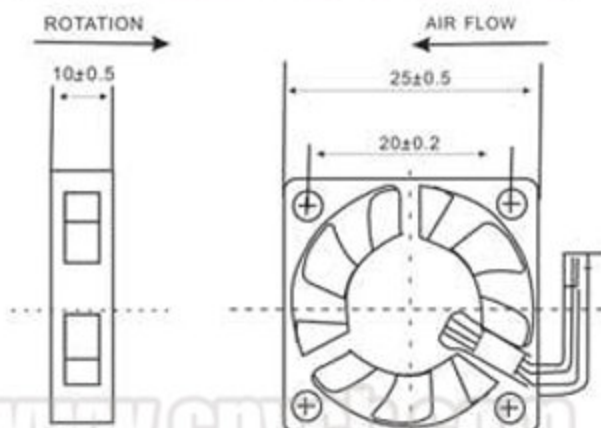

| 型号 | 轴承形式 | 电压 | 启动电压 | 电流 | 转数 | 风量 | 风压 | 噪声 |
|------------|------------------|------------|----------------|---------------|-------------|----------------|-----------------|-------------|
| Model | Bearing system:x | Volt (VDC) | starup Voltage | Rated current | Speed (RPM) | Air Flow (CFM) | Static Pressure | Noise (dBA) |
| IB-D2510HS | S | 05/12 | 3.0/6.0 | 0.16/0.10 | 13000 | 3.0 | 6.8 | 30 |
| IB-D2510MS | S | 05/12 | 3.0/6.0 | 0.12/0.08 | 10000 | 2.3 | 4.8 | 23 |
| IB-D2510LS | S | 05/12 | 3.0/6.0 | 0.08/0.06 | 7000 | 1.4 | 2.2 | 19 |
| IB-D2510HB | B | 05/12 | 3.0/6.0 | 0.16/0.10 | 13000 | 3.0 | 6.8 | 30 |
| IB-D2510MB | B | 05/12 | 3.0/6.0 | 0.12/0.08 | 10000 | 2.3 | 4.8 | 23 |
| IB-D2510LB | B | 05/12 | 3.0/6.0 | 0.08/0.06 | 7000 | 1.4 | 2.2 | 19 |

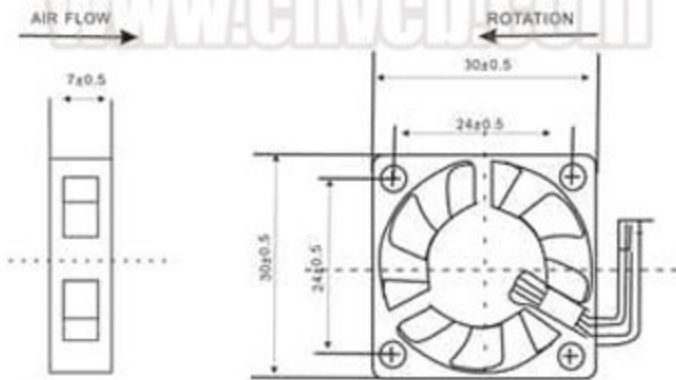

| 型号 | 轴承形式 | 电压 | 启动电压 | 电流 | 转数 | 风量 | 风压 | 噪声 |
|------------|------------------|------------|----------------|---------------|-------------|----------------|-----------------|-------------|
| Model | Bearing system:x | Volt (VDC) | starup Voltage | Rated current | Speed (RPM) | Air Flow (CFM) | Static Pressure | Noise (dBA) |
| IB-D3006HS | S | 5/12 | 3.0/5.0 | 0.14/0.07 | 10000 | 3.92 | 5.9 | 29 |
| IB-D3006MS | S | 5/12 | 3.0/5.0 | 0.12/0.06 | 9000 | 3.06 | 4.3 | 23 |
| IB-D3006LS | S | 5/12 | 3.0/5.0 | 0.10/0.05 | 8000 | 2.29 | 2.8 | 17 |
| IB-D3006HB | B | 5/12 | 3.0/5.0 | 0.14/0.07 | 10000 | 3.92 | 5.9 | 29 |
| IB-D3006MB | B | 5/12 | 3.0/5.0 | 0.12/0.06 | 9000 | 3.06 | 4.3 | 23 |
| IB-D3006LB | B | 5/12 | 3.0/5.0 | 0.10/0.05 | 8000 | 2.29 | 2.8 | 17 |

DC 系列 IB-D3010

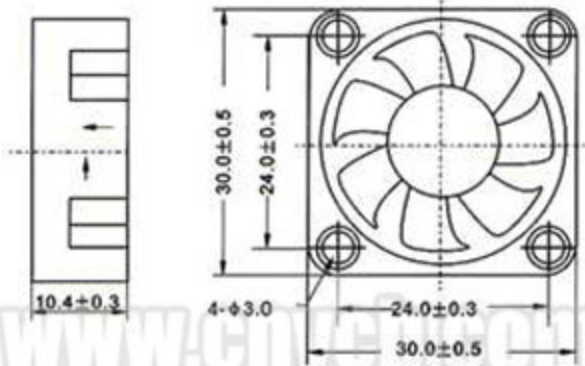

| 型号 | 轴承形式 | 电压 | 启动电压 | 电流 | 转数 | 风量 | 风压 | 噪声 |
|------------|------------------|------------|----------------|---------------|-------------|----------------|-----------------|-------------|
| Model | Bearing system:x | Volt (VDC) | starup Voltage | Rated current | Speed (RPM) | Air Flow (CFM) | Static Pressure | Noise (dBA) |
| IB-D3010HS | S | 5/12 | 3.0/6.0 | 0.20/0.10 | 11000 | 5.2 | 5.9 | 32 |
| IB-D3010MS | S | 5/12 | 3.0/6.0 | 0.14/0.09 | 9000 | 4.3 | 4.3 | 27 |
| IB-D3010LS | S | 5/12 | 3.0/6.0 | 0.12/0.06 | 7000 | 3.2 | 2.8 | 23 |
| IB-D3010HB | B | 5/12 | 3.0/6.0 | 0.20/0.10 | 11000 | 5.2 | 5.9 | 32 |
| IB-D3010MB | B | 5/12 | 3.0/6.0 | 0.14/0.09 | 9000 | 4.3 | 4.3 | 27 |
| IB-D3010LB | B | 5/12 | 3.0/6.0 | 0.12/0.06 | 7000 | 3.2 | 2.8 | 23 |

DC 系列 IB-D4010 - 1

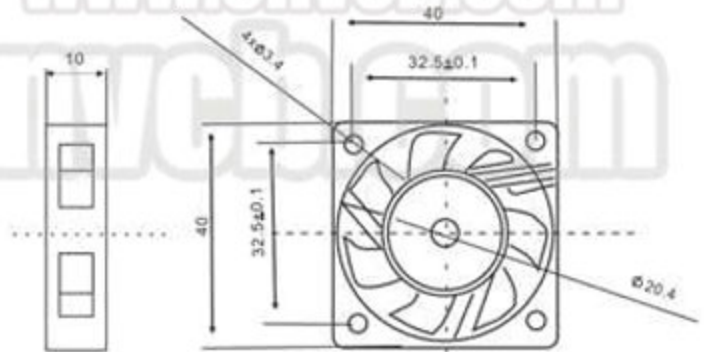

| 型号 | 轴承形式 | 电压 | 启动电压 | 电流 | 转数 | 风量 | 风压 | 噪声 |
|------------|------------------|------------|----------------|----------------|-------------|----------------|-----------------|-------------|
| Model | Bearing system:x | Volt (VDC) | starup Voltage | Rated current | Speed (RPM) | Air Flow (CFM) | Static Pressure | Noise (dBA) |
| IB-D4010HS | S | 5/12/24 | 3.0/6.0/12.0 | 0.20/0.09/0.09 | 8000 | 8.4 | 5.2 | 33 |
| IB-D4010MS | S | 5/12/24 | 3.0/6.0/12.0 | 0.16/0.07/0.07 | 6000 | 6.8 | 3.6 | 28 |
| IB-D4010LS | S | 5/12/24 | 3.0/6.0/12.0 | 0.13/0.06/0.06 | 4000 | 5.2 | 2.5 | 24 |
| IB-D4010HB | B | 5/12/24 | 3.0/6.0/12.0 | 0.20/0.09/0.09 | 8000 | 8.4 | 5.2 | 33 |
| IB-D4010MB | B | 5/12/24 | 3.0/6.0/12.0 | 0.16/0.07/0.07 | 6000 | 6.8 | 3.6 | 28 |
| IB-D4010LB | B | 5/12/24 | 3.0/6.0/12.0 | 0.13/0.06/0.06 | 4000 | 5.2 | 2.5 | 24 |

DC 系列 IB-D4010-2

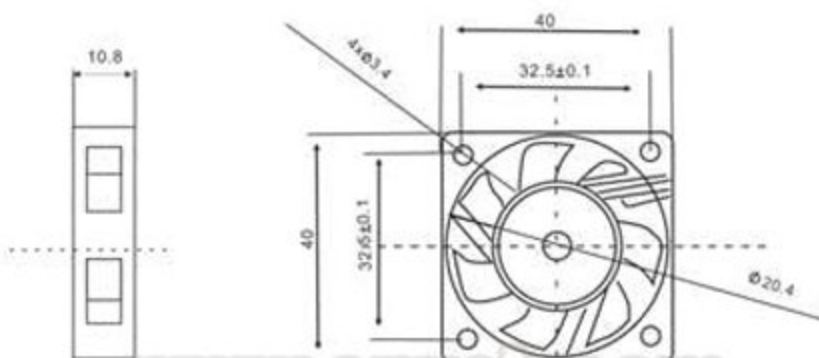

| 型号 | 轴承形式 | 电压 | 启动电压 | 电流 | 转数 | 风量 | 风压 | 噪声 |
|------------|------------------|------------|----------------|----------------|-------------|----------------|-----------------|-------------|
| Model | Bearing system:x | Volt (VDC) | starup Voltage | Rated current | Speed (RPM) | Air Flow (CFM) | Static Pressure | Noise (dBA) |
| IB-D4010HS | S | 5/12/24 | 3.0/6.0/12.0 | 0.20/0.09/0.09 | 8000 | 8.4 | 5.2 | 33 |
| IB-D4010MS | S | 5/12/24 | 3.0/6.0/12.0 | 0.16/0.07/0.07 | 6000 | 6.8 | 3.6 | 28 |
| IB-D4010LS | S | 5/12/24 | 3.0/6.0/12.0 | 0.13/0.06/0.06 | 4000 | 5.2 | 2.5 | 24 |
| IB-D4010HB | B | 5/12/24 | 3.0/6.0/12.0 | 0.20/0.09/0.09 | 8000 | 8.4 | 5.2 | 33 |
| IB-D4010MB | B | 5/12/24 | 3.0/6.0/12.0 | 0.16/0.07/0.07 | 6000 | 6.8 | 3.6 | 28 |
| IB-D4010LB | B | 5/12/24 | 3.0/6.0/12.0 | 0.13/0.06/0.06 | 4000 | 5.2 | 2.5 | 24 |

DC 系列 IB-D4015-1

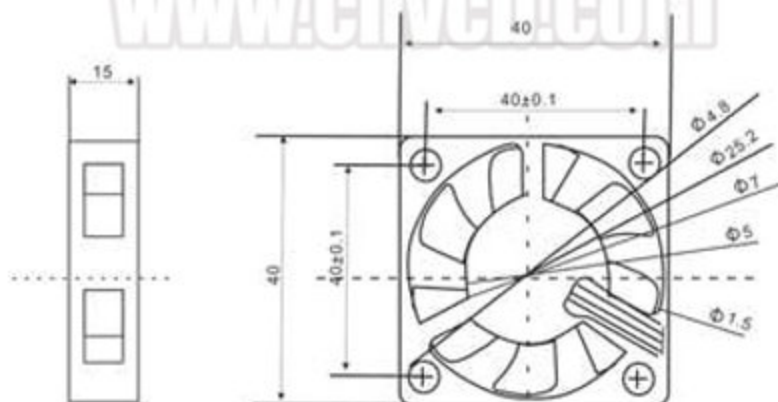

| 型号 | 轴承形式 | 电压 | 启动电压 | 电流 | 转数 | 风量 | 风压 | 噪声 |
|------------|------------------|------------|----------------|----------------|-------------|----------------|-----------------|-------------|
| Model | Bearing system:x | Volt (VDC) | starup Voltage | Rated current | Speed (RPM) | Air Flow (CFM) | Static Pressure | Noise (dBA) |
| IB-D4015HS | S | 5/12/24 | 3.0/6.0/12.0 | 0.20/0.09/0.09 | 8800 | 10.8 | 8.8 | 37 |
| IB-D4015MS | S | 5/12/24 | 3.0/6.0/12.0 | 0.16/0.07/0.07 | 6600 | 8.3 | 5.0 | 30 |
| IB-D4015LS | S | 5/12/24 | 3.0/6.0/12.0 | 0.13/0.06/0.06 | 4400 | 5.8 | 2.5 | 21 |
| IB-D4015HB | B | 5/12/24 | 3.0/6.0/12.0 | 0.20/0.09/0.09 | 8800 | 10.8 | 8.8 | 37 |
| IB-D4015MB | B | 5/12/24 | 3.0/6.0/12.0 | 0.16/0.07/0.07 | 6600 | 8.3 | 5.0 | 30 |
| IB-D4015LB | B | 5/12/24 | 3.0/6.0/12.0 | 0.13/0.06/0.06 | 4400 | 5.8 | 2.5 | 24 |

DC 系列 IB-D4015-2

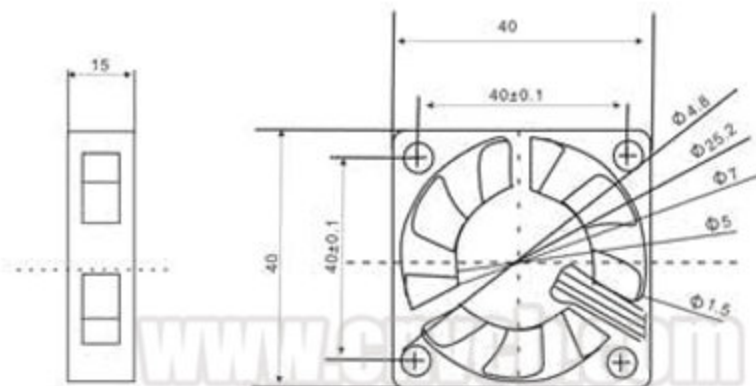

| 型号 | 轴承形式 | 电压 | 启动电压 | 电流 | 转速 | 风量 | 风压 | 噪声 |
|------------|------------------|------------|----------------|----------------|-------------|----------------|-----------------|-------------|
| Model | Bearing system:x | Volt (VDC) | starup Voltage | Rated current | Speed (RPM) | Air Flow (CFM) | Static Pressure | Noise (dBA) |
| IB-D4015HS | S | 5/12/24 | 3.0/6.0/12.0 | 0.20/0.09/0.09 | 8800 | 10.8 | 8.8 | 37 |
| IB-D4015MS | S | 5/12/24 | 3.0/6.0/12.0 | 0.16/0.07/0.07 | 6600 | 8.3 | 5.0 | 30 |
| IB-D4015LS | S | 5/12/24 | 3.0/6.0/12.0 | 0.13/0.06/0.06 | 4400 | 5.8 | 2.5 | 21 |
| IB-D4015HB | B | 5/12/24 | 3.0/6.0/12.0 | 0.20/0.09/0.09 | 8800 | 10.8 | 8.8 | 37 |
| IB-D4015MB | B | 5/12/24 | 3.0/6.0/12.0 | 0.16/0.07/0.07 | 6600 | 8.3 | 5.0 | 30 |
| IB-D4015LB | B | 5/12/24 | 3.0/6.0/12.0 | 0.13/0.06/0.06 | 4400 | 5.8 | 2.5 | 24 |

DC 系列 IB-D4020-1

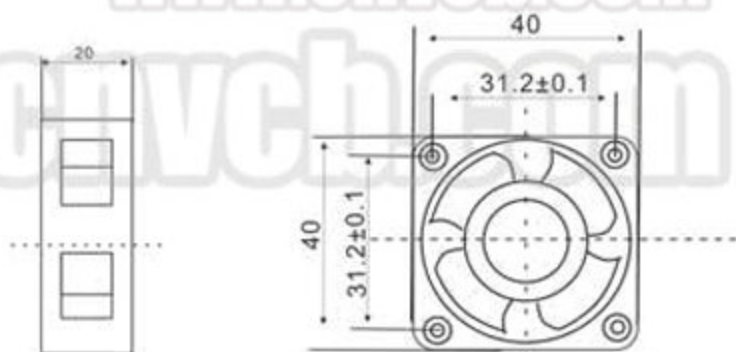

| 型号 | 轴承形式 | 电压 | 启动电压 | 电流 | 转速 | 风量 | 风压 | 噪声 |
|------------|------------------|------------|----------------|----------------|-------------|----------------|-----------------|-------------|
| Model | Bearing system:x | Volt (VDC) | starup Voltage | Rated current | Speed (RPM) | Air Flow (CFM) | Static Pressure | Noise (dBA) |
| IB-D4020HS | S | 5/12/24 | 3.0/6.0/12.0 | 0.28/0.10/0.07 | 7500 | 8.1 | 6.9 | 31 |
| IB-D4020MS | S | 5/12/24 | 3.0/6.0/12.0 | 0.25/0.08/0.06 | 6200 | 6.6 | 4.7 | 27 |
| IB-D4020LS | S | 5/12/24 | 3.0/6.0/12.0 | 0.20/0.06/0.05 | 5000 | 5.3 | 3.1 | 23 |
| IB-D4020HB | B | 5/12/24 | 3.0/6.0/12.0 | 0.28/0.10/0.07 | 7500 | 8.1 | 6.9 | 31 |
| IB-D4020MB | B | 5/12/24 | 3.0/6.0/12.0 | 0.25/0.08/0.06 | 6200 | 6.6 | 4.7 | 27 |
| IB-D4020LB | B | 5/12/24 | 3.0/6.0/12.0 | 0.20/0.06/0.05 | 5000 | 5.3 | 3.1 | 23 |

DC 系列 IB-D4020-2

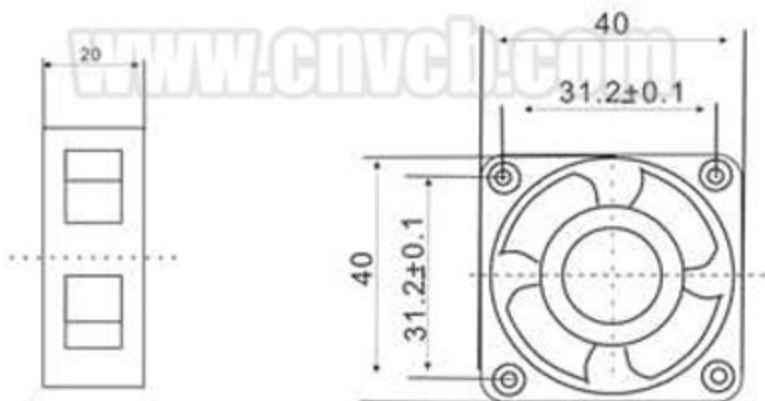

| 型号 | 轴承形式 | 电压 | 启动电压 | 电流 | 转数 | 风量 | 风压 | 噪声 |
|------------|------------------|------------|----------------|----------------|-------------|----------------|-----------------|-------------|
| Model | Bearing system:x | Volt (VDC) | starup Voltage | Rated current | Speed (RPM) | Air Flow (CFM) | Static Pressure | Noise (dBA) |
| IB-D4020HS | S | 5/12/24 | 3.0/6.0/12.0 | 0.28/0.10/0.07 | 7500 | 8.1 | 6.9 | 31 |
| IB-D4020MS | S | 5/12/24 | 3.0/6.0/12.0 | 0.25/0.08/0.06 | 6200 | 6.6 | 4.7 | 27 |
| IB-D4020LS | S | 5/12/24 | 3.0/6.0/12.0 | 0.20/0.06/0.05 | 5000 | 5.3 | 3.1 | 23 |
| IB-D4020HB | B | 5/12/24 | 3.0/6.0/12.0 | 0.28/0.10/0.07 | 7500 | 8.1 | 6.9 | 31 |
| IB-D4020MB | B | 5/12/24 | 3.0/6.0/12.0 | 0.25/0.08/0.06 | 6200 | 6.6 | 4.7 | 27 |
| IB-D4020LB | B | 5/12/24 | 3.0/6.0/12.0 | 0.20/0.06/0.05 | 5000 | 5.3 | 3.1 | 23 |

DC 系列 IB-D4510

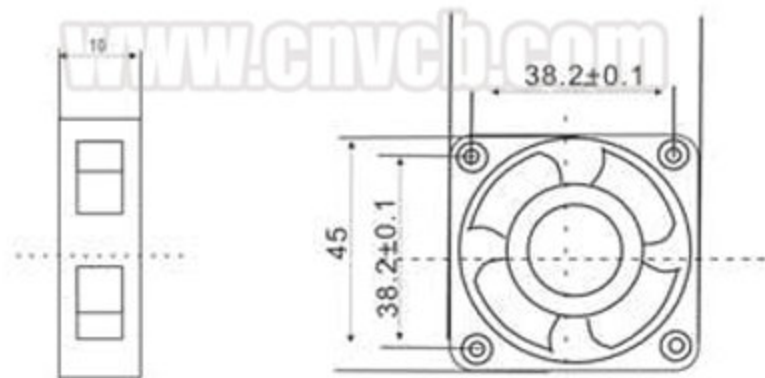

| 型号 | 轴承形式 | 电压 | 启动电压 | 电流 | 转数 | 风量 | 风压 | 噪声 |
|------------|------------------|------------|----------------|----------------|-------------|----------------|-----------------|-------------|
| Model | Bearing system:x | Volt (VDC) | starup Voltage | Rated current | Speed (RPM) | Air Flow (CFM) | Static Pressure | Noise (dBA) |
| IB-D4510HS | S | 5/12/24 | 3.0/6.0/12.0 | 0.20/0.09/0.09 | 8000 | 8.4 | 5.2 | 33 |
| IB-D4510MS | S | 5/12/24 | 3.0/6.0/12.0 | 0.16/0.07/0.07 | 6000 | 6.8 | 3.6 | 28 |
| IB-D4510LS | S | 5/12/24 | 3.0/6.0/12.0 | 0.13/0.06/0.06 | 4000 | 5.2 | 2.5 | 24 |
| IB-D4510HB | B | 5/12/24 | 3.0/6.0/12.0 | 0.20/0.09/0.09 | 8000 | 8.4 | 5.2 | 33 |
| IB-D4510MB | B | 5/12/24 | 3.0/6.0/12.0 | 0.16/0.07/0.07 | 6000 | 6.8 | 3.6 | 28 |
| IB-D4510LB | B | 5/12/24 | 3.0/6.0/12.0 | 0.13/0.06/0.06 | 4000 | 5.2 | 2.5 | 24 |

DC 系列 IB-D5010-1

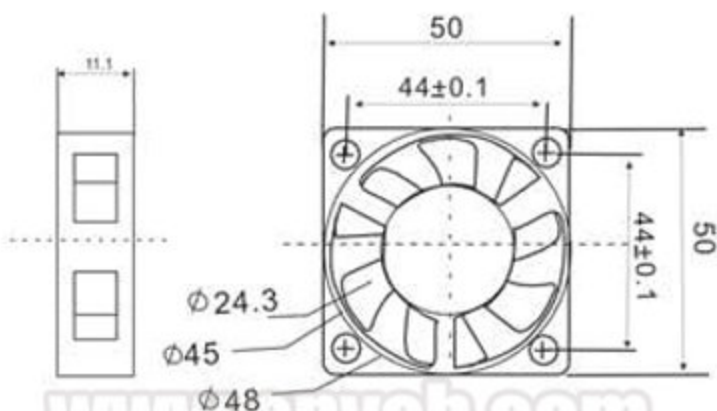

| 型号 | 轴承形式 | 电压 | 启动电压 | 电流 | 转数 | 风量 | 风压 | 噪声 |
|------------|------------------|------------|----------------|---------------|-------------|----------------|-----------------|-------------|
| Model | Bearing system:x | Volt (VDC) | starup Voltage | Rated current | Speed (RPM) | Air Flow (CFM) | Static Pressure | Noise (dBA) |
| IB-D5010HS | S | 05/12 | 3.0/6.0 | 0.23/0.16 | 6500 | 13.1 | 3.4 | 32 |
| IB-D5010MS | S | 05/12 | 3.0/6.0 | 0.18/0.08 | 5000 | 11.6 | 2.5 | 28 |
| IB-D5010LS | S | 05/12 | 3.0/6.0 | 0.14/0.07 | 3500 | 8.6 | 1.6 | 22 |
| IB-D5010HB | B | 05/12 | 3.0/6.0 | 0.23/0.16 | 6500 | 13.1 | 3.4 | 32 |
| IB-D5010MB | B | 05/12 | 3.0/6.0 | 0.18/0.08 | 5000 | 11.6 | 2.5 | 28 |
| IB-D5010LB | B | 05/12 | 3.0/6.0 | 0.14/0.07 | 3500 | 8.6 | 1.6 | 22 |

DC 系列 IB-D5010-2

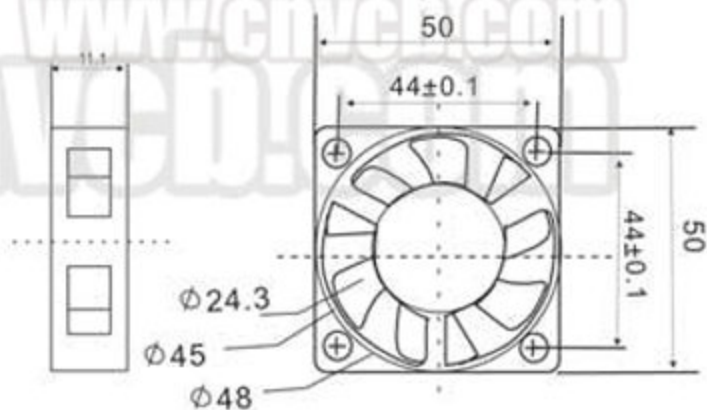

| 型号 | 轴承形式 | 电压 | 启动电压 | 电流 | 转数 | 风量 | 风压 | 噪声 |
|------------|------------------|------------|----------------|---------------|-------------|----------------|-----------------|-------------|
| Model | Bearing system:x | Volt (VDC) | starup Voltage | Rated current | Speed (RPM) | Air Flow (CFM) | Static Pressure | Noise (dBA) |
| IB-D5010HS | S | 5/12 | 3.0/6.0 | 0.23/0.16 | 6500 | 13.9 | 3.4 | 32 |
| IB-D5010MS | S | 5/12 | 3.0/6.0 | 0.18/0.09 | 5000 | 11.6 | 2.5 | 28 |
| IB-D5010LS | S | 5/12 | 3.0/6.0 | 0.14/0.07 | 3500 | 8.6 | 1.6 | 22 |
| IB-D5010HB | B | 5/12 | 3.0/6.0 | 0.23/0.16 | 6500 | 13.9 | 3.4 | 32 |
| IB-D5010MB | B | 5/12 | 3.0/6.0 | 0.18/0.09 | 5000 | 11.6 | 2.5 | 28 |
| IB-D5010LB | B | 5/12 | 3.0/6.0 | 0.14/0.07 | 3500 | 8.6 | 1.6 | 22 |

DC 系列 IB-D5015

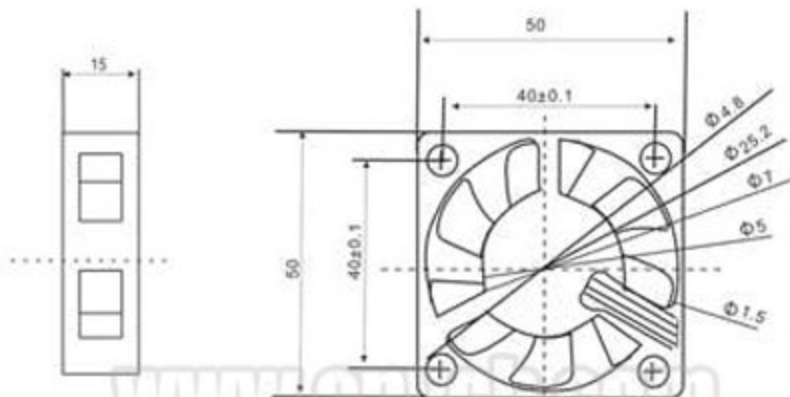

| 型号 | 轴承形式 | 电压 | 启动电压 | 电流 | 转数 | 风量 | 风压 | 噪声 |
|------------|------------------|------------|----------------|----------------|-------------|----------------|-----------------|-------------|
| Model | Bearing system:x | Volt (VDC) | starup Voltage | Rated current | Speed (RPM) | Air Flow (CFM) | Static Pressure | Noise (dBA) |
| IB-D5015HS | S | 5/12/24 | 3.0/6.0/12.0 | 0.32/0.16/0.10 | 6000 | 13.9 | 4.4 | 32 |
| IB-D5015MS | S | 5/12/24 | 3.0/6.0/12.0 | 0.25/0.14/0.08 | 5000 | 12.4 | 4.1 | 30 |
| IB-D5015LS | S | 5/12/24 | 3.0/6.0/12.0 | 0.20/0.12/0.06 | 4000 | 11.0 | 3.0 | 27 |
| IB-D5015HB | B | 5/12/24 | 3.0/6.0/12.0 | 0.32/0.16/0.10 | 6000 | 13.9 | 4.4 | 32 |
| IB-D5015MB | B | 5/12/24 | 3.0/6.0/12.0 | 0.25/0.14/0.08 | 5000 | 12.4 | 4.1 | 30 |
| IB-D5015LB | B | 5/12/24 | 3.0/6.0/12.0 | 0.20/0.12/0.06 | 4000 | 11.0 | 3.0 | 27 |

DC 系列 IB-D5020

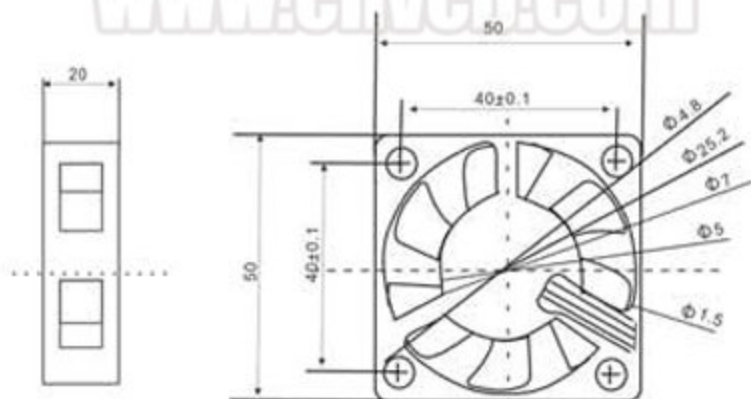

| 型号 | 轴承形式 | 电压 | 启动电压 | 电流 | 转数 | 风量 | 风压 | 噪声 |
|------------|------------------|------------|----------------|----------------|-------------|----------------|-----------------|-------------|
| Model | Bearing system:x | Volt (VDC) | starup Voltage | Rated current | Speed (RPM) | Air Flow (CFM) | Static Pressure | Noise (dBA) |
| IB-D5020HS | S | 5/12/24 | 3.0/6.0/12.0 | 0.28/0.10/0.07 | 7500 | 8.1 | 6.9 | 31 |
| IB-D5020MS | S | 5/12/24 | 3.0/6.0/12.0 | 0.25/0.08/0.06 | 6200 | 6.6 | 4.7 | 27 |
| IB-D5020LS | S | 5/12/24 | 3.0/6.0/12.0 | 0.20/0.06/0.05 | 5000 | 5.3 | 3.1 | 23 |
| IB-D5020HB | B | 5/12/24 | 3.0/6.0/12.0 | 0.28/0.10/0.07 | 7500 | 8.1 | 6.9 | 31 |
| IB-D5020MB | B | 5/12/24 | 3.0/6.0/12.0 | 0.25/0.08/0.06 | 6200 | 6.6 | 4.7 | 27 |
| IB-D5020LB | B | 5/12/24 | 3.0/6.0/12.0 | 0.20/0.06/0.05 | 5000 | 5.3 | 3.1 | 23 |

DC 系列 IB-D5025

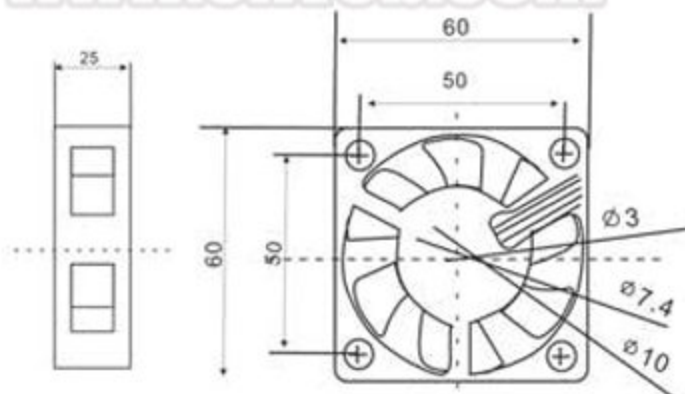

| 型号 | 轴承形式 | 电压 | 启动电压 | 电流 | 转数 | 风量 | 风压 | 噪声 |
|------------|------------------|------------|----------------|----------------|-------------|----------------|-----------------|-------------|
| Model | Bearing system:x | Volt (VDC) | starup Voltage | Rated current | Speed (RPM) | Air Flow (CFM) | Static Pressure | Noise (dBA) |
| IB-D5020HS | S | 5/12/24 | 3.0/6.0/12.0 | 0.28/0.10/0.07 | 7500 | 8.1 | 6.9 | 31 |
| IB-D5020MS | S | 5/12/24 | 3.0/6.0/12.0 | 0.25/0.08/0.06 | 6200 | 6.6 | 4.7 | 27 |
| IB-D5020LS | S | 5/12/24 | 3.0/6.0/12.0 | 0.20/0.06/0.05 | 5000 | 5.3 | 3.1 | 23 |
| IB-D5020HB | B | 5/12/24 | 3.0/6.0/12.0 | 0.28/0.10/0.07 | 7500 | 8.1 | 6.9 | 31 |
| IB-D5020MB | B | 5/12/24 | 3.0/6.0/12.0 | 0.25/0.08/0.06 | 6200 | 6.6 | 4.7 | 27 |
| IB-D5020LB | B | 5/12/24 | 3.0/6.0/12.0 | 0.20/0.06/0.05 | 5000 | 5.3 | 3.1 | 23 |

DC 系列 IB-D6010 - 1

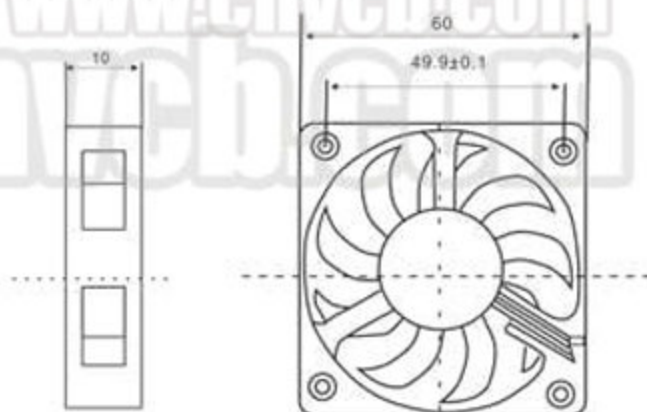

| 型号 | 轴承形式 | 电压 | 启动电压 | 电流 | 转数 | 风量 | 风压 | 噪声 |
|------------|------------------|------------|----------------|----------------|-------------|----------------|-----------------|-------------|
| Model | Bearing system:x | Volt (VDC) | starup Voltage | Rated current | Speed (RPM) | Air Flow (CFM) | Static Pressure | Noise (dBA) |
| IB-D6010HS | S | 5/12/24 | 3.0/6.0/12.0 | 0.35/0.22/0.11 | 4500 | 19.1 | 3.2 | 35 |
| IB-D6010MS | S | 5/12/24 | 3.0/6.0/12.0 | 0.22/0.17/0.09 | 3500 | 16.3 | 2.5 | 30 |
| IB-D6010LS | S | 5/12/24 | 3.0/6.0/12.0 | 0.17/0.14/0.07 | 2500 | 13.2 | 1.8 | 27 |
| IB-D6010HB | B | 5/12/24 | 3.0/6.0/12.0 | 0.35/0.22/0.11 | 4500 | 19.1 | 3.2 | 35 |
| IB-D6010MB | B | 5/12/24 | 3.0/6.0/12.0 | 0.22/0.17/0.09 | 3500 | 16.3 | 2.5 | 30 |
| IB-D6010LB | B | 5/12/24 | 3.0/6.0/12.0 | 0.17/0.14/0.07 | 2500 | 13.2 | 1.8 | 27 |

DC 系列 IB-D6010-2

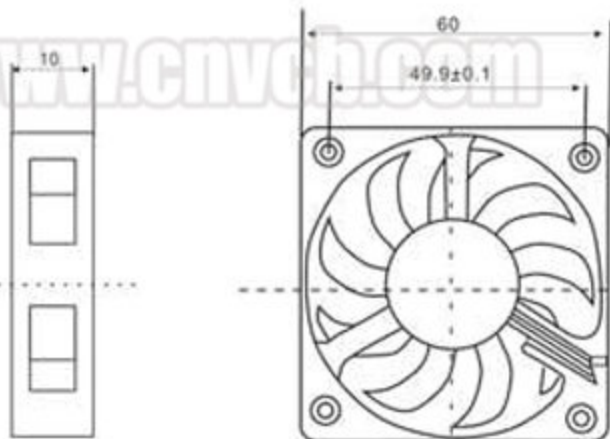

| 型号 | 轴承形式 | 电压 | 启动电压 | 电流 | 转数 | 风量 | 风压 | 噪声 |
|------------|------------------|------------|----------------|----------------|-------------|----------------|-----------------|-------------|
| Model | Bearing system:x | Volt (VDC) | starup Voltage | Rated current | Speed (RPM) | Air Flow (CFM) | Static Pressure | Noise (dBA) |
| IB-D6010HS | S | 5/12/24 | 3.0/6.0/12.0 | 0.35/0.22/0.11 | 4500 | 19.1 | 3.2 | 35 |
| IB-D6010MS | S | 5/12/24 | 3.0/6.0/12.0 | 0.22/0.17/0.09 | 3500 | 16.3 | 2.5 | 30 |
| IB-D6010LS | S | 5/12/24 | 3.0/6.0/12.0 | 0.17/0.14/0.07 | 2500 | 13.2 | 1.8 | 27 |
| IB-D6010HB | B | 5/12/24 | 3.0/6.0/12.0 | 0.35/0.22/0.11 | 4500 | 19.1 | 3.2 | 35 |
| IB-D6010MB | B | 5/12/24 | 3.0/6.0/12.0 | 0.22/0.17/0.09 | 3500 | 16.3 | 2.5 | 30 |
| IB-D6010LB | B | 5/12/24 | 3.0/6.0/12.0 | 0.17/0.14/0.07 | 2500 | 13.2 | 1.8 | 27 |

DC 系列 IB-D6010-3

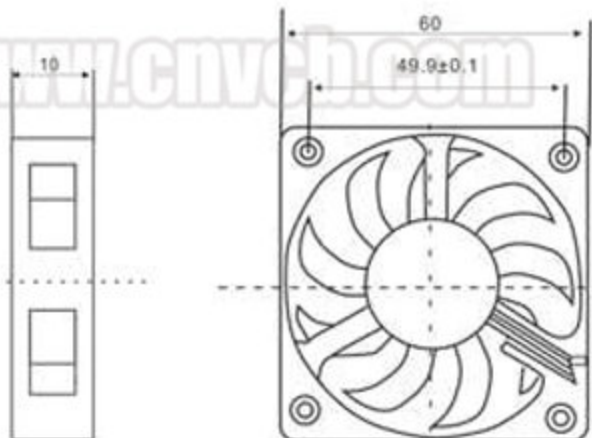

| 型号 | 轴承形式 | 电压 | 启动电压 | 电流 | 转数 | 风量 | 风压 | 噪声 |
|------------|------------------|------------|----------------|----------------|-------------|----------------|-----------------|-------------|
| Model | Bearing system:x | Volt (VDC) | starup Voltage | Rated current | Speed (RPM) | Air Flow (CFM) | Static Pressure | Noise (dBA) |
| IB-D6010HS | S | 5/12/24 | 3.0/6.0/12.0 | 0.35/0.22/0.11 | 4500 | 19.1 | 3.2 | 35 |
| IB-D6010MS | S | 5/12/24 | 3.0/6.0/12.0 | 0.22/0.17/0.09 | 3500 | 16.3 | 2.5 | 30 |
| IB-D6010LS | S | 5/12/24 | 3.0/6.0/12.0 | 0.17/0.14/0.07 | 2500 | 13.2 | 1.8 | 27 |
| IB-D6010HB | B | 5/12/24 | 3.0/6.0/12.0 | 0.35/0.22/0.11 | 4500 | 19.1 | 3.2 | 35 |
| IB-D6010MB | B | 5/12/24 | 3.0/6.0/12.0 | 0.22/0.17/0.09 | 3500 | 16.3 | 2.5 | 30 |
| IB-D6010LB | B | 5/12/24 | 3.0/6.0/12.0 | 0.17/0.14/0.07 | 2500 | 13.2 | 1.8 | 27 |

DC 系列 IB-D6010 - 4

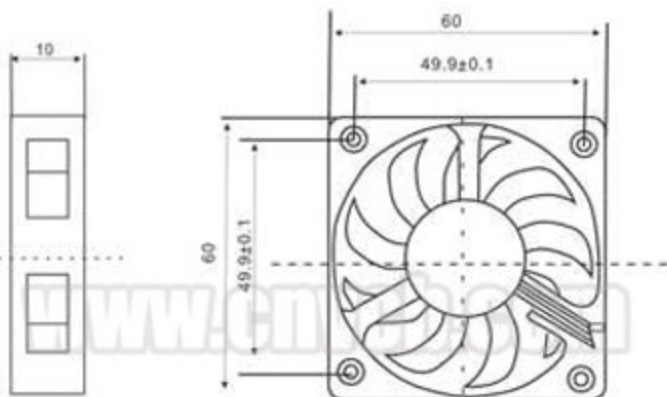

| 型号 | 轴承形式 | 电压 | 启动电压 | 电流 | 转速 | 风量 | 风压 | 噪声 |
|------------|------------------|------------|----------------|----------------|-------------|----------------|-----------------|-------------|
| Model | Bearing system:x | Volt (VDC) | starup Voltage | Rated current | Speed (RPM) | Air Flow (CFM) | Static Pressure | Noise (dBA) |
| IB-D6010HS | S | 5/12/24 | 3.0/6.0/12.0 | 0.35/0.22/0.11 | 4500 | 19.1 | 3.2 | 35 |
| IB-D6010MS | S | 5/12/24 | 3.0/6.0/12.0 | 0.22/0.17/0.09 | 3500 | 16.3 | 2.5 | 30 |
| IB-D6010LS | S | 5/12/24 | 3.0/6.0/12.0 | 0.17/0.14/0.07 | 2500 | 13.2 | 1.8 | 27 |
| IB-D6010HB | B | 5/12/24 | 3.0/6.0/12.0 | 0.35/0.22/0.11 | 4500 | 19.1 | 3.2 | 35 |
| IB-D6010MB | B | 5/12/24 | 3.0/6.0/12.0 | 0.22/0.17/0.09 | 3500 | 16.3 | 2.5 | 30 |
| IB-D6010LB | B | 5/12/24 | 3.0/6.0/12.0 | 0.17/0.14/0.07 | 2500 | 13.2 | 1.8 | 27 |

DC 系列 IB-D6015 - 1

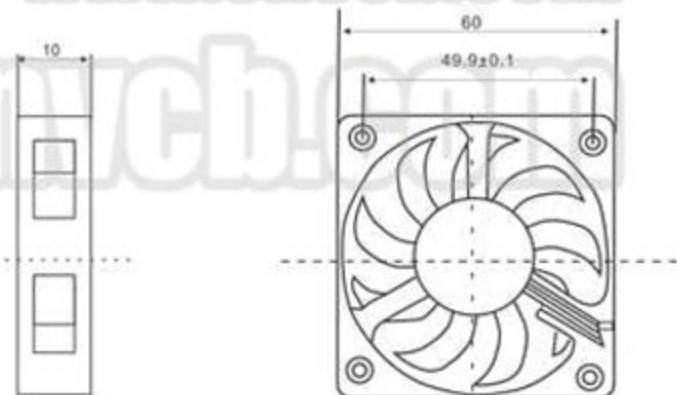

| 型号 | 轴承形式 | 电压 | 启动电压 | 电流 | 转速 | 风量 | 风压 | 噪声 |
|------------|------------------|------------|----------------|----------------|-------------|----------------|-----------------|-------------|
| Model | Bearing system:x | Volt (VDC) | starup Voltage | Rated current | Speed (RPM) | Air Flow (CFM) | Static Pressure | Noise (dBA) |
| IB-D6015HS | S | 5/12/24 | 3.0/6.0/12.0 | 0.40/0.17/0.15 | 4500 | 19.3 | 3.4 | 35 |
| IB-D6015MS | S | 5/12/24 | 3.0/6.0/12.0 | 0.25/0.15/0.10 | 4000 | 17.7 | 2.8 | 32 |
| IB-D6015LS | S | 5/12/24 | 3.0/6.0/12.0 | 0.15/0.11/0.08 | 3500 | 16.4 | 2.2 | 29 |
| IB-D6015HB | B | 5/12/24 | 3.0/6.0/12.0 | 0.40/0.17/0.15 | 4500 | 19.3 | 3.4 | 35 |
| IB-D6015MB | B | 5/12/24 | 3.0/6.0/12.0 | 0.25/0.15/0.10 | 4000 | 17.7 | 2.8 | 32 |
| IB-D6015LB | B | 5/12/24 | 3.0/6.0/12.0 | 0.15/0.11/0.08 | 3500 | 16.4 | 2.2 | 29 |

DC 系列 IB-D6015-2

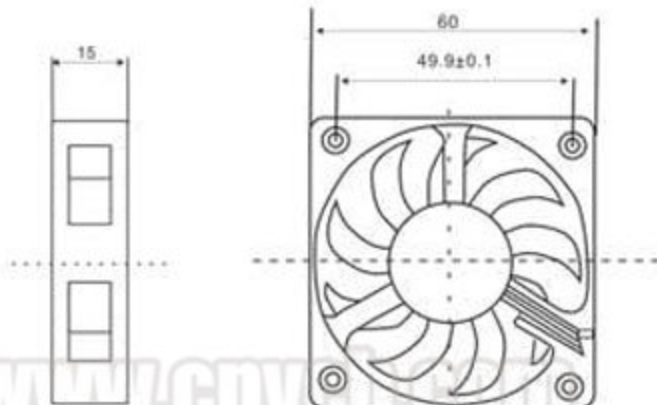

| 型号 | 轴承形式 | 电压 | 启动电压 | 电流 | 转数 | 风量 | 风压 | 噪声 |
|------------|------------------|------------|----------------|----------------|-------------|----------------|-----------------|-------------|
| Model | Bearing system:x | Volt (VDC) | starup Voltage | Rated current | Speed (RPM) | Air Flow (CFM) | Static Pressure | Noise (dBA) |
| IB-D6015HS | S | 5/12/24 | 3.0/6.0/12.0 | 0.40/0.17/0.15 | 4500 | 19.3 | 3.4 | 35 |
| IB-D6015MS | S | 5/12/24 | 3.0/6.0/12.0 | 0.25/0.15/0.10 | 4000 | 17.7 | 2.8 | 32 |
| IB-D6015LS | S | 5/12/24 | 3.0/6.0/12.0 | 0.15/0.11/0.08 | 3500 | 16.4 | 2.2 | 29 |
| IB-D6015HB | B | 5/12/24 | 3.0/6.0/12.0 | 0.40/0.17/0.15 | 4500 | 19.3 | 3.4 | 35 |
| IB-D6015MB | B | 5/12/24 | 3.0/6.0/12.0 | 0.25/0.15/0.10 | 4000 | 17.7 | 2.8 | 32 |
| IB-D6015LB | B | 5/12/24 | 3.0/6.0/12.0 | 0.15/0.11/0.08 | 3500 | 16.4 | 2.2 | 29 |

DC 系列 IB-D6020

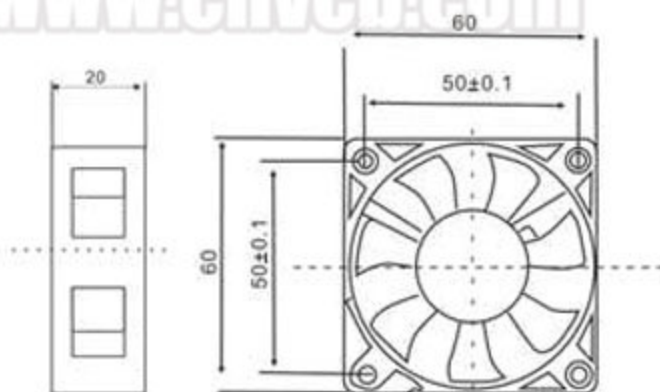

| 型号 | 轴承形式 | 电压 | 启动电压 | 电流 | 转数 | 风量 | 风压 | 噪声 |
|------------|------------------|------------|----------------|---------------|-------------|----------------|-----------------|-------------|
| Model | Bearing system:x | Volt (VDC) | starup Voltage | Rated current | Speed (RPM) | Air Flow (CFM) | Static Pressure | Noise (dBA) |
| IB-D6020HS | S | 12/24 | 6.0/12.0 | 0.16/0.13 | 4300 | 22.6 | 3.9 | 35 |
| IB-D6020MS | S | 12/24 | 6.0/12.0 | 0.12/0.10 | 3500 | 18.5 | 3.3 | 30 |
| IB-D6020LS | S | 12/24 | 6.0/12.0 | 0.08 | 3000 | 15.7 | 2.4 | 26 |
| IB-D6020HB | B | 12/24 | 6.0/12.0 | 0.16/0.13 | 4300 | 22.6 | 3.9 | 35 |
| IB-D6020MB | B | 12/24 | 6.0/12.0 | 0.12/0.10 | 3500 | 18.5 | 3.3 | 30 |
| IB-D6020LB | B | 12/24 | 6.0/12.0 | 0.08 | 3000 | 15.7 | 2.4 | 26 |

DC 系列 IB-D6025 - 1

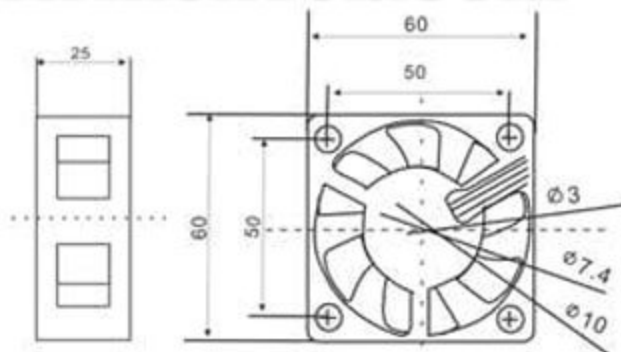

| 型号 | 轴承形式 | 电压 | 启动电压 | 电流 | 转数 | 风量 | 风压 | 噪声 |
|------------|------------------|------------|----------------|---------------|-------------|----------------|-----------------|-------------|
| Model | Bearing system:x | Volt (VDC) | starup Voltage | Rated current | Speed (RPM) | Air Flow (CFM) | Static Pressure | Noise (dBA) |
| IB-D6025HS | S | 12/24 | 6.0/12.0 | 0.14/0.15 | 4000 | 21.2 | 4.2 | 29 |
| IB-D6025MS | S | 12/24 | 6.0/12.0 | 0.10 | 3000 | 15.9 | 2.5 | 22 |
| IB-D6025LS | S | 12/24 | 6.0/12.0 | 0.07 | 2500 | 13.2 | 1.8 | 19 |
| IB-D6025HB | B | 12/24 | 6.0/12.0 | 0.14/0.15 | 4000 | 21.2 | 4.2 | 29 |
| IB-D6025MB | B | 12/24 | 6.0/12.0 | 0.10 | 3000 | 15.9 | 2.5 | 22 |
| IB-D6025LB | B | 12/24 | 6.0/12.0 | 0.07 | 2500 | 13.2 | 1.8 | 19 |

Dc系列 IB-D6025 - 2

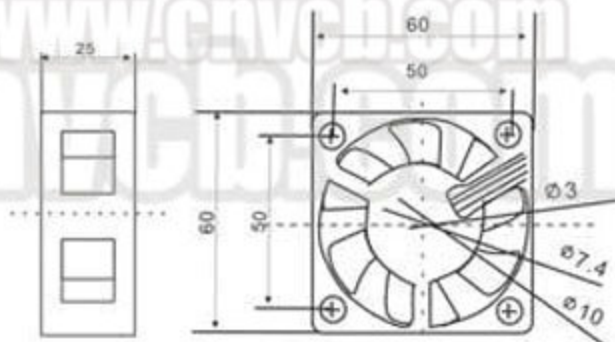

| 型号 | 轴承形式 | 电压 | 启动电压 | 电流 | 转数 | 风量 | 风压 | 噪声 |
|------------|------------------|------------|----------------|---------------|-------------|----------------|-----------------|-------------|
| Model | Bearing system:x | Volt (VDC) | starup Voltage | Rated current | Speed (RPM) | Air Flow (CFM) | Static Pressure | Noise (dBA) |
| IB-D6025HS | S | 12/24 | 6.0/12.0 | 0.14/0.15 | 4000 | 21.2 | 4.2 | 29 |
| IB-D6025MS | S | 12/24 | 6.0/12.0 | 0.10 | 3000 | 15.9 | 2.5 | 22 |
| IB-D6025LS | S | 12/24 | 6.0/12.0 | 0.07 | 2500 | 13.2 | 1.8 | 19 |
| IB-D6025HB | B | 12/24 | 6.0/12.0 | 0.14/0.15 | 4000 | 21.2 | 4.2 | 29 |
| IB-D6025MB | B | 12/24 | 6.0/12.0 | 0.10 | 3000 | 15.9 | 2.5 | 22 |
| IB-D6025LB | B | 12/24 | 6.0/12.0 | 0.07 | 2500 | 13.2 | 1.8 | 19 |

DC 系列 IB-D7015

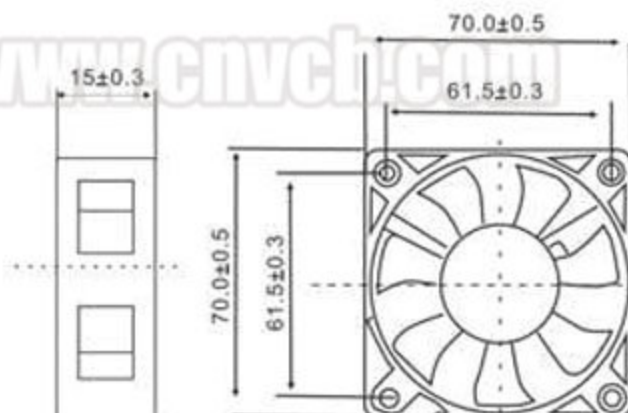

| 型号 | 轴承形式 | 电压 | 启动电压 | 电流 | 转速 | 风量 | 风压 | 噪声 |
|------------|------------------|------------|----------------|---------------|-------------|----------------|-----------------|-------------|
| Model | Bearing system:x | Volt (VDC) | starup Voltage | Rated current | Speed (RPM) | Air Flow (CFM) | Static Pressure | Noise (dBA) |
| IB-D7015HS | S | 12/24 | 6.0/12.0 | 0.28/0.25 | 4500 | 39.4 | 4.3 | 39 |
| IB-D7015MS | S | 12/24 | 6.0/12.0 | 0.14/0.16 | 3500 | 27.8 | 2.2 | 33 |
| IB-D7015LS | S | 12/24 | 6.0/12.0 | 0.11/0.12 | 2500 | 19.9 | 1.8 | 26 |
| IB-D7015HB | B | 12/24 | 6.0/12.0 | 0.28/0.25 | 4500 | 39.4 | 4.3 | 39 |
| IB-D7015MB | B | 12/24 | 6.0/12.0 | 0.14/0.16 | 3500 | 27.8 | 2.2 | 33 |
| IB-D7015LB | B | 12/24 | 6.0/12.0 | 0.11/0.12 | 2500 | 19.9 | 1.8 | 26 |

DC 系列 IB-D7025

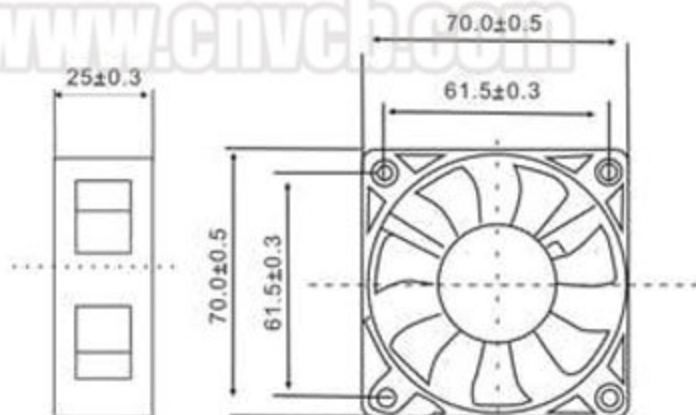

| 型号 | 轴承形式 | 电压 | 启动电压 | 电流 | 转速 | 风量 | 风压 | 噪声 |
|------------|------------------|------------|----------------|----------------|-------------|----------------|-----------------|-------------|
| Model | Bearing system:x | Volt (VDC) | starup Voltage | Rated current | Speed (RPM) | Air Flow (CFM) | Static Pressure | Noise (dBA) |
| IB-D7025HS | S | 5/12/24 | 3.0/6.0/12.0 | 0.55/0.40/0.22 | 4000 | 31.5 | 4.9 | 36 |
| IB-D7025MS | S | 5/12/24 | 3.0/6.0/12.0 | 0.30/0.20/0.12 | 3000 | 23.7 | 3.1 | 28 |
| IB-D7025LS | S | 5/12/24 | 3.0/6.0/12.0 | 0.22/0.15/0.10 | 2500 | 19.7 | 2.8 | 26 |
| IB-D7025HB | B | 5/12/24 | 3.0/6.0/12.0 | 0.55/0.40/0.22 | 4000 | 31.5 | 4.9 | 36 |
| IB-D7025MB | B | 5/12/24 | 3.0/6.0/12.0 | 0.30/0.20/0.12 | 3000 | 23.7 | 3.1 | 28 |
| IB-D7025LB | B | 5/12/24 | 3.0/6.0/12.0 | 0.22/0.15/0.10 | 2500 | 19.7 | 2.8 | 26 |

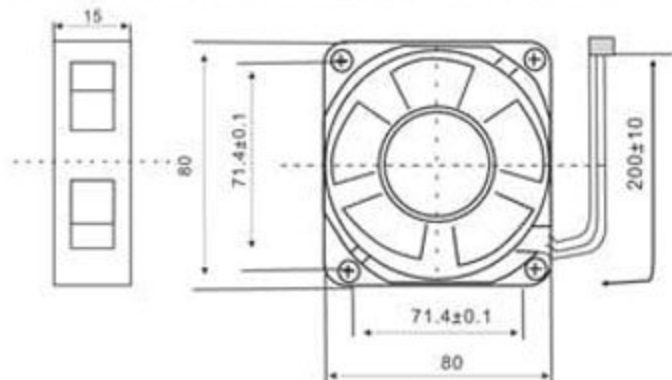

| 型号 | 轴承形式 | 电压 | 启动电压 | 电流 | 转速 | 风量 | 风压 | 噪声 |
|------------|------------------|------------|----------------|---------------|-------------|----------------|-----------------|-------------|
| Model | Bearing system:x | Volt (VDC) | starup Voltage | Rated current | Speed (RPM) | Air Flow (CFM) | Static Pressure | Noise (dBA) |
| IB-D8015HS | S | 12/24 | 06/12 | 0.27/0.15 | 4100/3000 | 49.6/34.1 | 5.8 | 42/34 |
| IB-D8015MS | S | 12/24 | 06/12 | 0.17/0.13 | 3000/2500 | 27.9/22.6 | 5.8 | 34/29 |
| IB-D8015LS | S | 12/24 | 06/12 | 0.09/0.10 | 2500/2000 | 49.6/34.1 | 3.0 | 24 |
| IB-D8015HB | B | 12/24 | 06/12 | 0.27/0.15 | 4100/3000 | 27.9/22.6 | 3.0 | 42/34 |
| IB-D8015MB | B | 12/24 | 06/12 | 0.17/0.13 | 3000/2500 | 49.6/34.1 | 2.4 | 34/29 |
| IB-D8015LB | B | 12/24 | 06/12 | 0.09/0.10 | 2500/2000 | 27.9/22.6 | 2.4 | 24 |

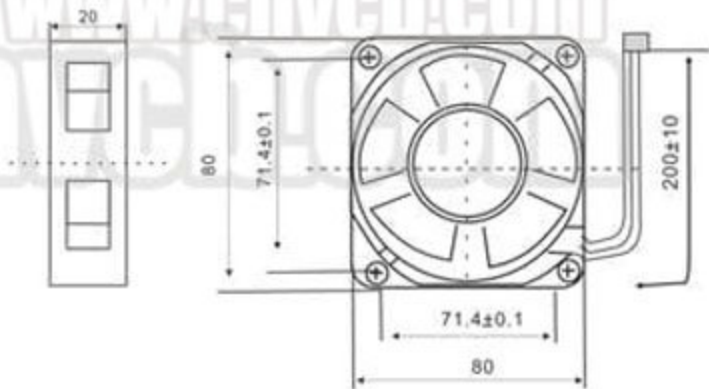

| 型号 | 轴承形式 | 电压 | 启动电压 | 电流 | 转速 | 风量 | 风压 | 噪声 |
|------------|------------------|------------|----------------|---------------|-------------|----------------|-----------------|-------------|
| Model | Bearing system:x | Volt (VDC) | starup Voltage | Rated current | Speed (RPM) | Air Flow (CFM) | Static Pressure | Noise (dBA) |
| IB-D8020HS | S | 12/24 | 6.0/12.0 | 0.23/0.21 | 3500 | 38.8 | 3.3 | 40 |
| IB-D8020MS | S | 12/24 | 6.0/12.0 | 0.17/0.14 | 3000 | 33.5 | 2.4 | 35 |
| IB-D8020LS | S | 12/24 | 6.0/12.0 | 0.13/0.12 | 2500 | 27.6 | 1.7 | 30 |
| IB-D8020HB | B | 12/24 | 6.0/12.0 | 0.23/0.21 | 3500 | 38.8 | 3.3 | 40 |
| IB-D8020MB | B | 12/24 | 6.0/12.0 | 0.17/0.14 | 3000 | 33.5 | 2.4 | 35 |
| IB-D8020LB | B | 12/24 | 6.0/12.0 | 0.13/0.12 | 2500 | 27.6 | 1.7 | 30 |

DC 系列 IB-D8020 半框

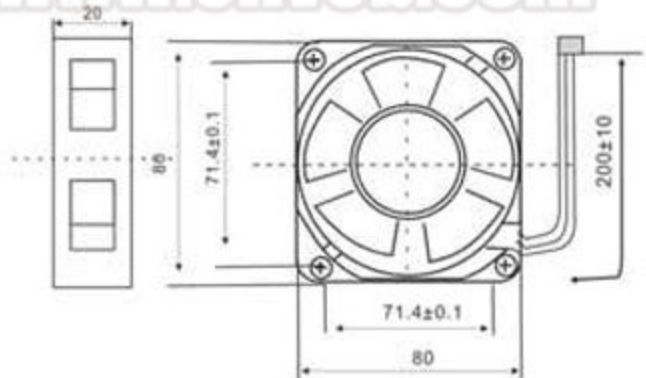

| 型号 | 轴承形式 | 电压 | 启动电压 | 电流 | 转速 | 风量 | 风压 | 噪声 |
|------------|------------------|------------|----------------|---------------|-------------|----------------|-----------------|-------------|
| Model | Bearing system:x | Volt (VDC) | starup Voltage | Rated current | Speed (RPM) | Air Flow (CFM) | Static Pressure | Noise (dBA) |
| IB-D8020HS | S | 12/24 | 6.0/12.0 | 0.23/0.21 | 3500 | 38.8 | 3.3 | 40 |
| IB-D8020MS | S | 12/24 | 6.0/12.0 | 0.17/0.14 | 3000 | 33.5 | 2.4 | 35 |
| IB-D8020LS | S | 12/24 | 6.0/12.0 | 0.13/0.12 | 2500 | 27.6 | 1.7 | 30 |
| IB-D8020HB | B | 12/24 | 6.0/12.0 | 0.23/0.21 | 3500 | 38.8 | 3.3 | 40 |
| IB-D8020MB | B | 12/24 | 6.0/12.0 | 0.17/0.14 | 3000 | 33.5 | 2.4 | 35 |
| IB-D8020LB | B | 12/24 | 6.0/12.0 | 0.13/0.12 | 2500 | 27.6 | 1.7 | 30 |

DC 系列 IB-D8025 - 1

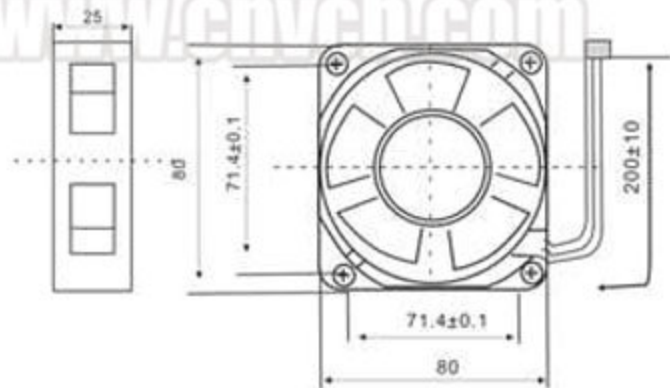

| 型号 | 轴承形式 | 电压 | 启动电压 | 电流 | 转速 | 风量 | 风压 | 噪声 |
|------------|------------------|------------|----------------|----------------|-------------|----------------|-----------------|-------------|
| Model | Bearing system:x | Volt (VDC) | starup Voltage | Rated current | Speed (RPM) | Air Flow (CFM) | Static Pressure | Noise (dBA) |
| IB-D8025HS | S | 5/12/24 | 3.0/6.0/12.0 | 0.40/0.17/0.15 | 3000 | 30.1 | 4.3 | 30 |
| IB-D8025MS | S | 5/12/24 | 3.0/6.0/12.0 | 0.28/0.11/0.12 | 2500 | 24.3 | 2.6 | 28 |
| IB-D8025LS | S | 5/12/24 | 3.0/6.0/12.0 | 0.22/0.08/0.09 | 2000 | 20.0 | 1.9 | 21 |
| IB-D8025HB | B | 5/12/24 | 3.0/6.0/12.0 | 0.40/0.17/0.15 | 3000 | 30.1 | 4.3 | 30 |
| IB-D8025MB | B | 5/12/24 | 3.0/6.0/12.0 | 0.28/0.11/0.12 | 2500 | 24.3 | 2.6 | 28 |
| IB-D8025LB | B | 5/12/24 | 3.0/6.0/12.0 | 0.22/0.08/0.09 | 2000 | 20.0 | 1.9 | 21 |

DC 系列 IB-D8025-2

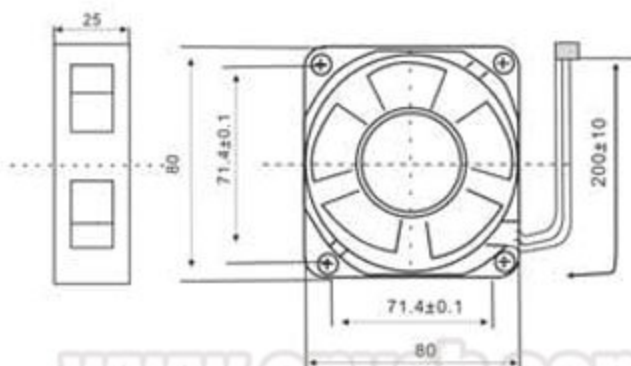

| 型号 | 轴承形式 | 电压 | 启动电压 | 电流 | 转数 | 风量 | 风压 | 噪声 |
|------------|------------------|------------|----------------|----------------|-------------|----------------|-----------------|-------------|
| Model | Bearing system:x | Volt (VDC) | starup Voltage | Rated current | Speed (RPM) | Air Flow (CFM) | Static Pressure | Noise (dBA) |
| IB-D8025HS | S | 5/12/24 | 3.0/6.0/12.0 | 0.40/0.17/0.15 | 3000 | 30.1 | 4.3 | 30 |
| IB-D8025MS | S | 5/12/24 | 3.0/6.0/12.0 | 0.28/0.11/0.12 | 2500 | 24.3 | 2.6 | 28 |
| IB-D8025LS | S | 5/12/24 | 3.0/6.0/12.0 | 0.22/0.08/0.09 | 2000 | 20.0 | 1.9 | 21 |
| IB-D8025HB | B | 5/12/24 | 3.0/6.0/12.0 | 0.40/0.17/0.15 | 3000 | 30.1 | 4.3 | 30 |
| IB-D8025MB | B | 5/12/24 | 3.0/6.0/12.0 | 0.28/0.11/0.12 | 2500 | 24.3 | 2.6 | 28 |
| IB-D8025LB | B | 5/12/24 | 3.0/6.0/12.0 | 0.22/0.08/0.09 | 2000 | 20.0 | 1.9 | 21 |

DC 系列 IB-D8025-3

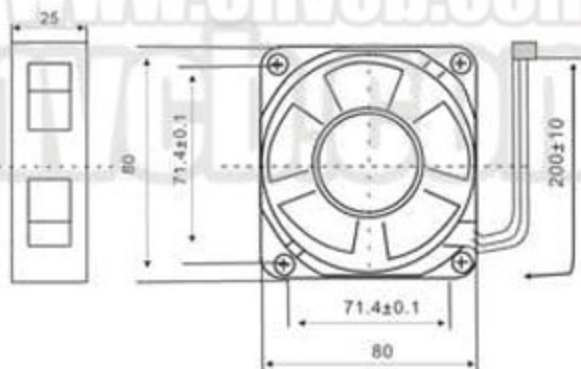

| 型号 | 轴承形式 | 电压 | 启动电压 | 电流 | 转数 | 风量 | 风压 | 噪声 |
|------------|------------------|------------|----------------|----------------|-------------|----------------|-----------------|-------------|
| Model | Bearing system:x | Volt (VDC) | starup Voltage | Rated current | Speed (RPM) | Air Flow (CFM) | Static Pressure | Noise (dBA) |
| IB-D8025HS | S | 5/12/24 | 3.0/6.0/12.0 | 0.40/0.17/0.15 | 3000 | 30.1 | 4.3 | 30 |
| IB-D8025MS | S | 5/12/24 | 3.0/6.0/12.0 | 0.28/0.11/0.12 | 2500 | 24.3 | 2.6 | 28 |
| IB-D8025LS | S | 5/12/24 | 3.0/6.0/12.0 | 0.22/0.08/0.09 | 2000 | 20.0 | 1.9 | 21 |
| IB-D8025HB | B | 5/12/24 | 3.0/6.0/12.0 | 0.40/0.17/0.15 | 3000 | 30.1 | 4.3 | 30 |
| IB-D8025MB | B | 5/12/24 | 3.0/6.0/12.0 | 0.28/0.11/0.12 | 2500 | 24.3 | 2.6 | 28 |
| IB-D8025LB | B | 5/12/24 | 3.0/6.0/12.0 | 0.22/0.08/0.09 | 2000 | 20.0 | 1.9 | 21 |

DC 系列 IB-D8025-4

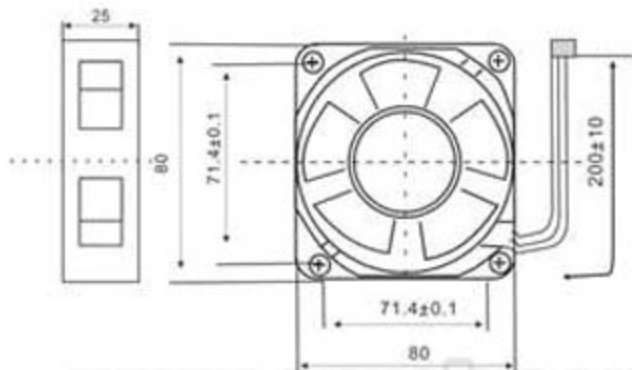

| 型号 | 轴承形式 | 电压 | 启动电压 | 电流 | 转数 | 风量 | 风压 | 噪声 |
|------------|------------------|------------|----------------|----------------|-------------|----------------|-----------------|-------------|
| Model | Bearing system:x | Volt (VDC) | starup Voltage | Rated current | Speed (RPM) | Air Flow (CFM) | Static Pressure | Noise (dBA) |
| IB-D8025HS | S | 5/12/24 | 3.0/6.0/12.0 | 0.40/0.17/0.15 | 3000 | 30.1 | 4.3 | 30 |
| IB-D8025MS | S | 5/12/24 | 3.0/6.0/12.0 | 0.28/0.11/0.12 | 2500 | 24.3 | 2.6 | 28 |
| IB-D8025LS | S | 5/12/24 | 3.0/6.0/12.0 | 0.22/0.08/0.09 | 2000 | 20.0 | 1.9 | 21 |
| IB-D8025HB | B | 5/12/24 | 3.0/6.0/12.0 | 0.40/0.17/0.15 | 3000 | 30.1 | 4.3 | 30 |
| IB-D8025MB | B | 5/12/24 | 3.0/6.0/12.0 | 0.28/0.11/0.12 | 2500 | 24.3 | 2.6 | 28 |
| IB-D8025LB | B | 5/12/24 | 3.0/6.0/12.0 | 0.22/0.08/0.09 | 2000 | 20.0 | 1.9 | 21 |

DC 系列 IB-D9225

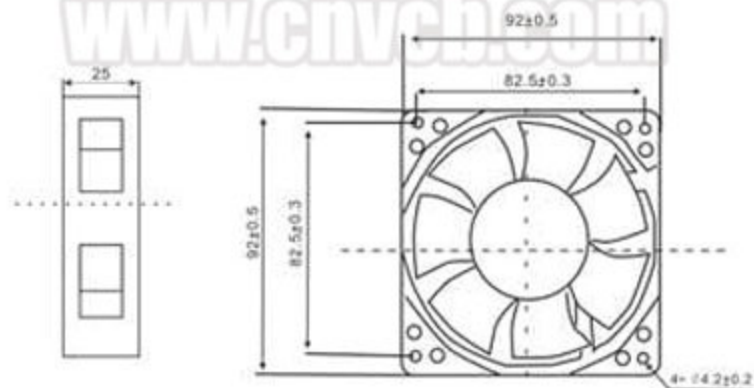

| 型号 | 轴承形式 | 电压 | 启动电压 | 电流 | 转数 | 风量 | 风压 | 噪声 |
|------------|------------------|------------|----------------|---------------|-------------|----------------|-----------------|-------------|
| Model | Bearing system:x | Volt (VDC) | starup Voltage | Rated current | Speed (RPM) | Air Flow (CFM) | Static Pressure | Noise (dBA) |
| IB-D9225HS | S | 12/24 | 6.0/12.0 | 0.23/0.22 | 3000 | 34.1 | 2.2 | 35 |
| IB-D9225MS | S | 12/24 | 6.0/12.0 | 0.19/0.18 | 2500 | 31.3 | 1.9 | 31 |
| IB-D9225LS | S | 12/24 | 6.0/12.0 | 0.16/0.15 | 2000 | 25.6 | 1.2 | 26 |
| IB-D9225HB | B | 12/24 | 6.0/12.0 | 0.23/0.22 | 3000 | 34.1 | 2.2 | 35 |
| IB-D9225MB | B | 12/24 | 6.0/12.0 | 0.19/0.18 | 2500 | 31.3 | 1.9 | 31 |
| IB-D9225LB | B | 12/24 | 6.0/12.0 | 0.16/0.15 | 2000 | 25.6 | 1.2 | 26 |

DC 系列 IB-D9238

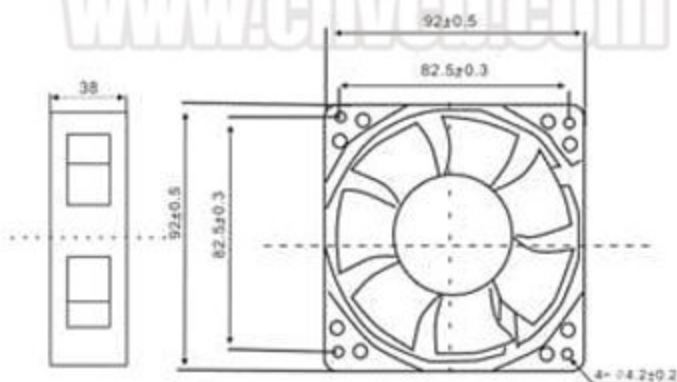

| 型号 | 轴承形式 | 电压 | 启动电压 | 电流 | 转数 | 风量 | 风压 | 噪声 |
|------------|------------------|------------|----------------|---------------|-------------|----------------|-----------------|-------------|
| Model | Bearing system:x | Volt (VDC) | starup Voltage | Rated current | Speed (RPM) | Air Flow (CFM) | Static Pressure | Noise (dBA) |
| IB-D9238HS | S | 12/24 | 6.0/12.0 | 0.23/0.22 | 3000 | 34.1 | 2.2 | 35 |
| IB-D9238MS | S | 12/24 | 6.0/12.0 | 0.19/0.18 | 2500 | 31.3 | 1.9 | 31 |
| IB-D9238LS | S | 12/24 | 6.0/12.0 | 0.16/0.15 | 2000 | 25.6 | 1.2 | 26 |
| IB-D9238HB | B | 12/24 | 6.0/12.0 | 0.23/0.22 | 3000 | 34.1 | 2.2 | 35 |
| IB-D9238MB | B | 12/24 | 6.0/12.0 | 0.19/0.18 | 2500 | 31.3 | 1.9 | 31 |
| IB-D9238LB | B | 12/24 | 6.0/12.0 | 0.16/0.15 | 2000 | 25.6 | 1.2 | 26 |

DC 系列 IB-D12025 小芯

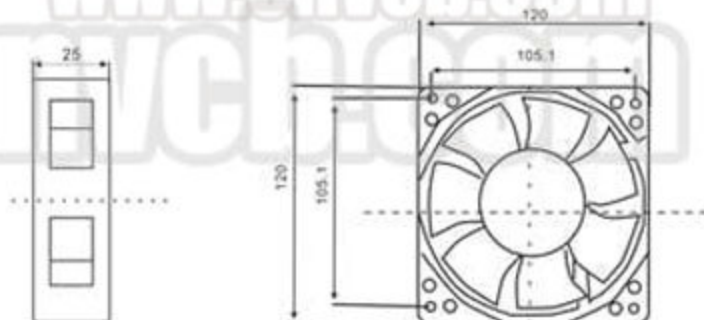

| 型号 | 轴承形式 | 电压 | 启动电压 | 电流 | 转数 | 风量 | 风压 | 噪声 |
|-------------|------------------|------------|----------------|----------------|-------------|----------------|-----------------|-------------|
| Model | Bearing system:x | Volt (VDC) | starup Voltage | Rated current | Speed (RPM) | Air Flow (CFM) | Static Pressure | Noise (dBA) |
| IB-D12025HS | S | 12/24/48 | 6.0/12.0/24 | 0.40/0.35/0.30 | 2400 | 92.3 | 4.4 | 41 |
| IB-D12025MS | S | 12/24/48 | 6.0/12.0/24 | 0.23/0.20/0.24 | 2000 | 76.4 | 3.2 | 35 |
| IB-D12025LS | S | 12/24/48 | 6.0/12.0/24 | 0.18/0.13/0.15 | 1700 | 60.5 | 2.3 | 32 |
| IB-D12025HB | B | 12/24/48 | 6.0/12.0/24 | 0.40/0.35/0.30 | 2400 | 116.8 | 4.9 | 41/43 |
| IB-D12025MB | B | 12/24/48 | 6.0/12.0/24 | 0.23/0.20/0.24 | 2000 | 96.1 | 4.5 | 35/42 |
| IB-D12025LB | B | 12/24/48 | 6.0/12.0/24 | 0.18/0.13/0.15 | 1700 | 76.4 | 3.2 | 32/35 |

DC 系列 IB-D12025 大芯

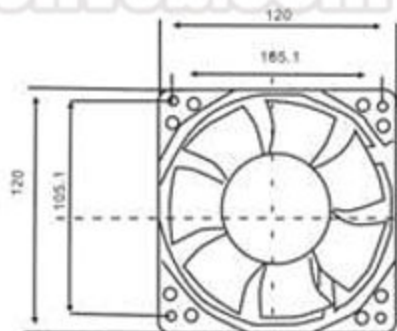
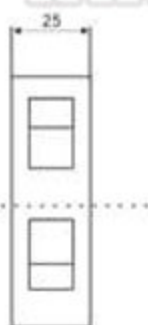

| 型号 | 轴承形式 | 电压 | 启动电压 | 电流 | 转速 | 风量 | 风压 | 噪声 |
|-------------|------------------|------------|----------------|----------------|-------------|----------------|-----------------|-------------|
| Model | Bearing system:x | Volt (VDC) | starup Voltage | Rated current | Speed (RPM) | Air Flow (CFM) | Static Pressure | Noise (dBA) |
| IB-D12025HS | S | 12/24/48 | 6.0/12.0/24 | 0.40/0.35/0.30 | 2400 | 92.3 | 4.4 | 41 |
| IB-D12025MS | S | 12/24/48 | 6.0/12.0/24 | 0.23/0.20/0.24 | 2000 | 76.4 | 3.2 | 35 |
| IB-D12025LS | S | 12/24/48 | 6.0/12.0/24 | 0.18/0.13/0.15 | 1700 | 60.5 | 2.3 | 32 |
| IB-D12025HB | B | 12/24/48 | 6.0/12.0/24 | 0.40/0.35/0.30 | 2400 | 116.8 | 4.9 | 41/43 |
| IB-D12025MB | B | 12/24/48 | 6.0/12.0/24 | 0.23/0.20/0.24 | 2000 | 96.1 | 4.5 | 35/42 |
| IB-D12025LB | B | 12/24/48 | 6.0/12.0/24 | 0.18/0.13/0.15 | 1700 | 76.4 | 3.2 | 32/35 |

DC 系列 IB-D120 - 电磁炉

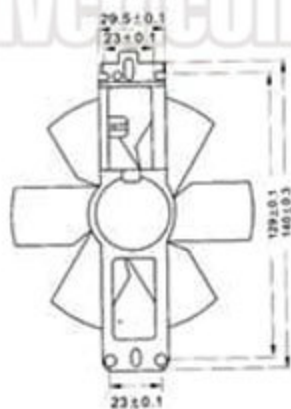

| 型号 | 轴承形式 | 电压 | 启动电压 | 电流 | 转速 | 风量 | 风压 | 噪声 |
|-------------|------------------|------------|----------------|---------------|-------------|----------------|-----------------|-------------|
| Model | Bearing system:x | Volt (VDC) | starup Voltage | Rated current | Speed (RPM) | Air Flow (CFM) | Static Pressure | Noise (dBA) |
| IB-D12025HX | S/B | 12 | 6 | 0.12 | 1600 | 52.03 | 2.92 | 25 |
| IB-D12025MX | S/B | 12 | 6 | 0.16 | 1800 | 59.03 | 3.33 | 27 |
| IB-D12025LX | S/B | 12 | 6 | 0.22 | 2000 | 65.55 | 3.65 | 30 |
| IB-D12025HX | S/B | 18 | 9 | 0.12 | 1600 | 52.03 | 2.92 | 25 |
| IB-D12025MX | S/B | 18 | 9 | 0.14 | 1800 | 59.03 | 3.33 | 27 |
| IB-D12025LX | S/B | 18 | 9 | 0.16 | 2000 | 65.55 | 3.65 | 30 |

DC 系列 IB-D12038 铝

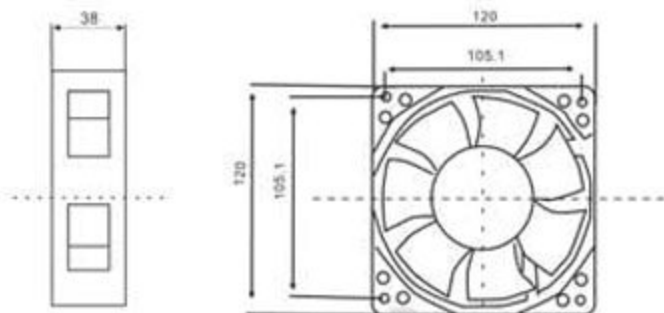

www.cnvcb.com

| 型号 | 轴承形式 | 电压 | 启动电压 | 电流 | 转速 | 风量 | 风压 | 噪声 |
|-------------|------------------|------------|----------------|----------------|-------------|----------------|-----------------|-------------|
| Model | Bearing system:x | Volt (VDC) | starup Voltage | Rated current | Speed (RPM) | Air Flow (CFM) | Static Pressure | Noise (dBA) |
| IB-D12038HS | S | 12/24/48 | 6.0/12.0/24.0 | 0.60/0.40/0.20 | 3000 | 126.6 | 7.8 | 44 |
| IB-D12038MS | S | 12/24/48 | 6.0/12.0/24.0 | 0.40/0.30/0.15 | 2500 | 102.4 | 5.3 | 39 |
| IB-D12038LS | S | 12/24/48 | 6.0/12.0/24.0 | 0.25/0.02/0.13 | 2000 | 83.2 | 3.7 | 34 |
| IB-D12038HB | B | 12/24/48 | 6.0/12.0/24.0 | 0.60/0.40/0.20 | 3000 | 126.6 | 7.8 | 30 |
| IB-D12038MB | B | 12/24/48 | 6.0/12.0/24.0 | 0.40/0.30/0.15 | 2500 | 102.4 | 5.3 | 28 |
| IB-D12038LB | B | 12/24/48 | 6.0/12.0/24.0 | 0.25/0.02/0.13 | 2000 | 83.2 | 3.7 | 21 |

DC 系列 IB-D12038

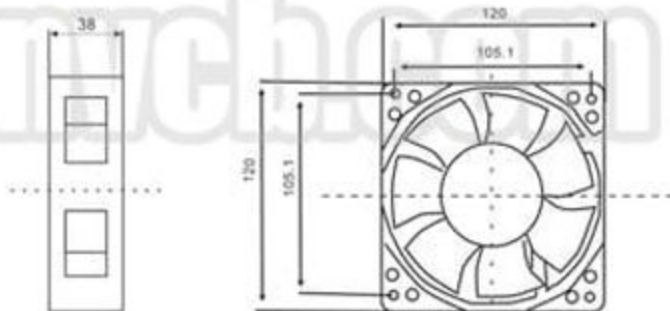

www.cnvcb.com

| 型号 | 轴承形式 | 电压 | 启动电压 | 电流 | 转速 | 风量 | 风压 | 噪声 |
|-------------|------------------|------------|----------------|----------------|-------------|----------------|-----------------|-------------|
| Model | Bearing system:x | Volt (VDC) | starup Voltage | Rated current | Speed (RPM) | Air Flow (CFM) | Static Pressure | Noise (dBA) |
| IB-D12038HS | S | 12/24/48 | 6.0/12.0/24.0 | 0.60/0.40/0.20 | 3000 | 126.6 | 7.8 | 44 |
| IB-D12038MS | S | 12/24/48 | 6.0/12.0/24.0 | 0.40/0.30/0.15 | 2500 | 102.4 | 5.3 | 39 |
| IB-D12038LS | S | 12/24/48 | 6.0/12.0/24.0 | 0.25/0.02/0.13 | 2000 | 83.2 | 3.7 | 34 |
| IB-D12038HB | B | 12/24/48 | 6.0/12.0/24.0 | 0.60/0.40/0.20 | 3000 | 126.6 | 7.8 | 30 |
| IB-D12038MB | B | 12/24/48 | 6.0/12.0/24.0 | 0.40/0.30/0.15 | 2500 | 102.4 | 5.3 | 28 |
| IB-D12038LB | B | 12/24/48 | 6.0/12.0/24.0 | 0.25/0.02/0.13 | 2000 | 83.2 | 3.7 | 21 |